

3-Phase Brushless Direct Current Motor Driver with Hall-Effect Sensor

Author: Andrey Magarita
Associated Project: Yes
Associated Part Family: CY8C27xxx
PSoC Designer Version: 4.1
Associated Application Notes:

Summary

This Application Note demonstrates how to use a PSoC™ to control a 3-phase Brushless Direct Current (BLDC) motor utilizing Hall-effect sensors.

Introduction

3-phase BLDC motors are widely used in modern electronic devices such as hard, floppy and CD-ROM PC drives as well as other consumer and industrial equipment. The motor operational principles are described in the “Handbook of Small Electric Motors,” [1] and summarized here.

BLDC motors have a straight-line, speed-torque curve similar to that of their mechanically commutated counterparts. In BLDC motors, the magnets rotate and the current-carrying coils are stationary. Electronic switches control current direction. The switch sequence and timing are established by a type of rotor-position sensor. Figure 1 shows the BLDC motor internals, which consist of a multi-pole permanent magnet rotor and a stator with multiple coils linked together using a triangle or star connection.

Several approaches can be used to obtain information about rotor position. Possible methods include sensor-less techniques, such as back electromagnetic force sensing; or sensor-based techniques, such as optical encoders and magnetic field sensors (inductor or Hall-effect based).

This note demonstrates the BLDC motor drive with Hall sensors. Table 1 lists the driver specifications.

Figure 2 demonstrates the motor operation. Each half-rotor revolution consists of six phases, so the rotor rotates 30° during each phase. The three bipolar, 120°-shifted voltage sources are used for motor control. These voltages can be true sinusoidal or step approximation of the sinewave signal.

In Figure 2b, the stator coils are shown symbolically. The coil winding method used for this Application Note is different from that shown in Figure 2b. However, the magnetic field generation is the same as shown in Figure 2a. The minus sign before the coil marks that the coil is wound in the opposite direction relative to the part, which is marked without a minus sign. Note that the coils formed by the magnetic field are non-uniform. They have maximum voltage at the pole center, with levels approximately two times higher than at the pole edges.

The 3-phase switching voltage forms the rotating magnetic field. Figure 2 illustrates the stator fields after phase-switching events. The six events (Event 1 – Event 6) mark the phase-switching moments. This figure shows clock-wise rotation marked by an arched arrow. To rotate the rotor counter clock-wise, the reverse phase-switching order is used and can be achieved by exchanging the switching order of any two motor coils. The polling order of the Hall sensors should be reversed as well.

The following notations are used in Figure 2: H1-H3 – Hall sensor output signals. Wph, Vph, Uph – phase W, V, U driving voltages.

WUph, VWph, UVph – voltages between phases WU, VW, UV.

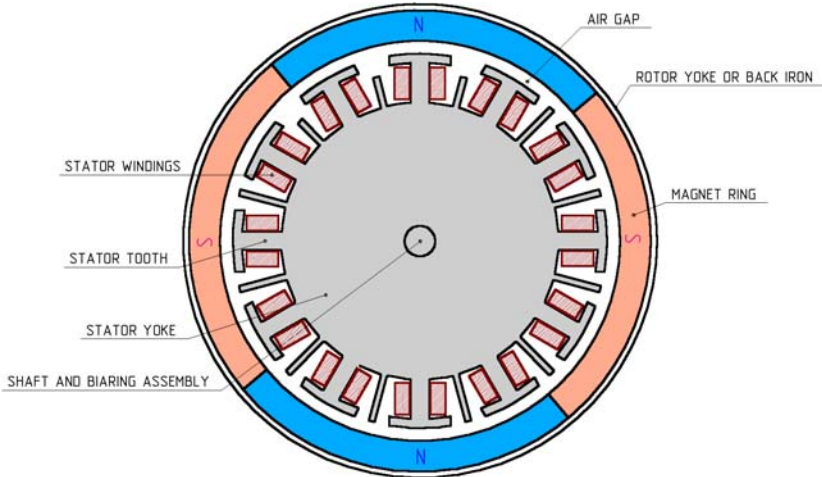

Figure 1. BLDC Motor Internals Outer-Rotor Version

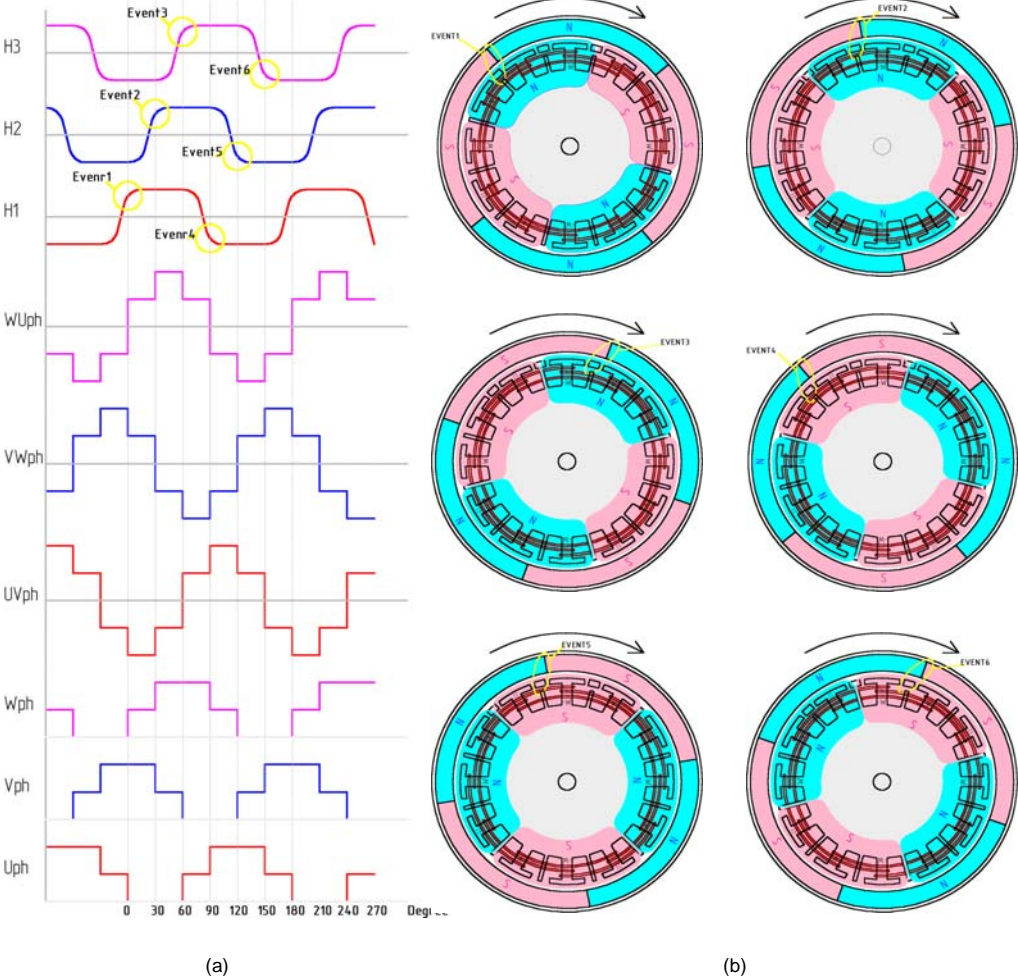

Figure 2. BLDC Coil Phase Voltage Switching (a) and Rotor Rotation Phases (b)

Driver Implementation

The BLDC motor driver has been implemented based on a PSoC device. The presence of analog capabilities greatly reduces the external components' count. Table 1 lists driver specifications.

Table 1. Driver Specifications

Motor Used	3" Floppy Drive with 12V Power Supply
Phases	3
Poles	4
Power Supply	12V DC
Power Consumption	350 mA
Rotation Speed	60-1200 rpm
Service Possibilities	Single button to change rotational direction;
	Two buttons to change rotational speed;
	Speed or driving torque stabilization modes.

The driver flowchart is shown in Figure 3. Signals from three Hall sensors with differential outputs are multiplexed by multiplexer MUX₁ and the differential signal is separated by the instrumentation amplifier, INA. Note that Hall sensors with differential outputs and without any internal post-processing internal hardware are used in this design to minimize the cost.

A differential amplifier output can be inverted using the multiplexer MUX₂ and compared to a reference signal using a comparator, COMP. The comparator generates interrupts, which are used by the CPU core to estimate rotor position. The CPU core controls the 3-channel PWM generator, which drives the winding motor via the coil's driver. An interval timer is used to measure the rotation speed and adjust the winding drive current according to the measured/demanded rotation speed value. The entire signal-processing pathway is implemented inside the PSoC; only the coil drivers are external.

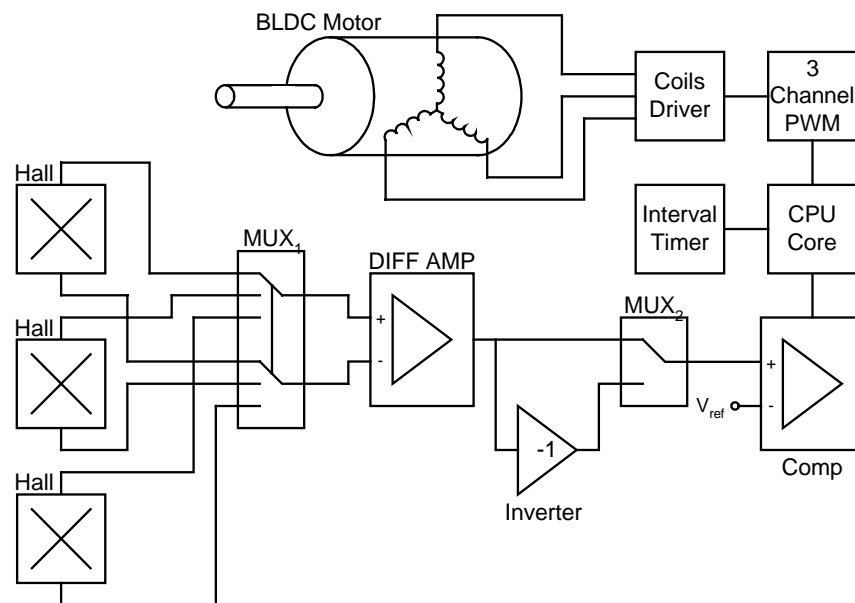

Figure 3. BLDC Motor Driver Flowchart

The Driver Schematic

Figure 4 illustrates the driver schematic. The driver consists of the PSoC, U₁, mode switch, SW₁, four buttons, SW₂-SW₅, a level translator, U₂, three 4-wire Hall sensors, E₁-E₃, and a linear regulator, U₃.

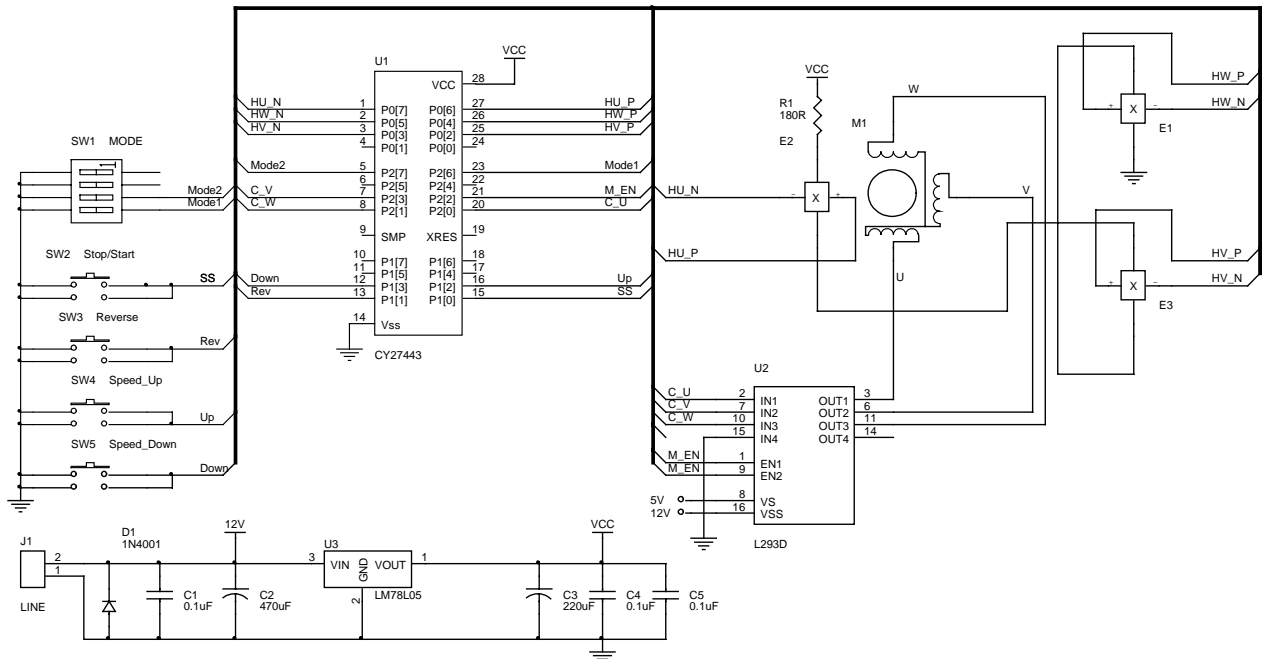

Figure 4. Motor Driver Schematic

The Driver Operation Details

Figure 5 shows the placement of the PSoC user modules. PSoC analog blocks are used to build the sensor's signal processing section and identify rotor-phase position. This section consists of:

- An instrumentation amplifier with differential multiplexer for sensor signal-level shifting and amplification
- A gain sign invert stage for signal rectification
- A comparator for rotor-phase switching interrupt generation

Comparator signal processing determines the current motor rotor phase.

PSoC digital blocks are used to build the three 8-bit PWM timers with variable incoming frequency (an additional 8-bit prescaler is used to generate the PWM module's clock signal). The 16-bit timer is used to measure the rotation speed of the motor. The phase shift between the output signal of the adjacent PWM timer is 120°. PWM timer outputs for different phases are listed in Table 2.

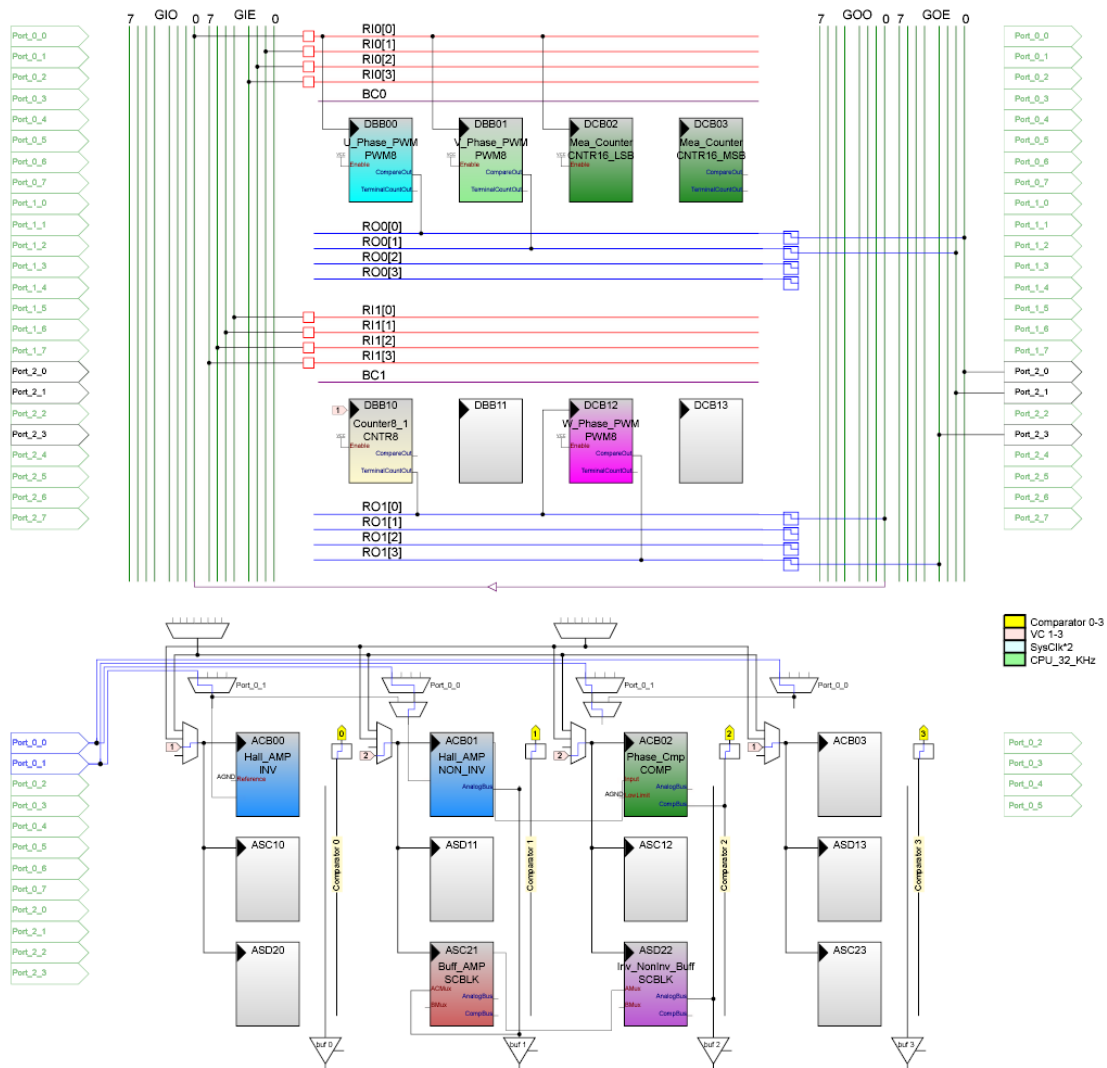

Figure 5. PSoC Internal User Module Placement

Table 2. Driver PWM Phase Signals

Output	Phase 1	Phase 2	Phase 3	Phase 4	Phase 5	Phase 6
Clock-wise Rotation						
U	H	H	M	L	L	M
V	L	M	H	H	M	L
W	M	L	L	M	H	H
U-V	2A	A	-A	-2A	-A	A
V-W	-A	A	2A	A	-A	-2A
W-U	-A	-2A	-A	A	2A	A
Counter Clock-wise Rotation						
U	H	H	M	L	L	M
V	M	L	L	M	H	H
W	L	M	H	H	M	L
U-V	A	2A	A	-A	-2A	-A
V-W	A	-A	-2A	-A	A	2A
W-U	-2A	-A	A	2A	A	-A

U, V, and W are the PWM timer phase outputs. U-V, V-W, and W-U are the motor winding levels. L is the minimum PWM value. H is the maximum PWM value. M is the middle PWM level. A equals H-M = M-L, or half the maximum PWM value of winding the motor. Table 2 and Figure 6a show that the PWM output signals assign a combination of 3 allowable voltage levels on the motor windings. These levels are shown in Figure 6b. According to Table 2, there are six possible rotation phases (states) and six corresponding PWM driver states.

The signal curve can be considered a 2-bit approximation of a triangle signal. The PWM timers work as one-shot devices. The one-shot rerun is implemented in software and triggered by motor rotor-phase change events. In the brushless DC motor, the rotation speed is determined by the construction of the motor: PWM timer output signal's duty cycle and current load value.

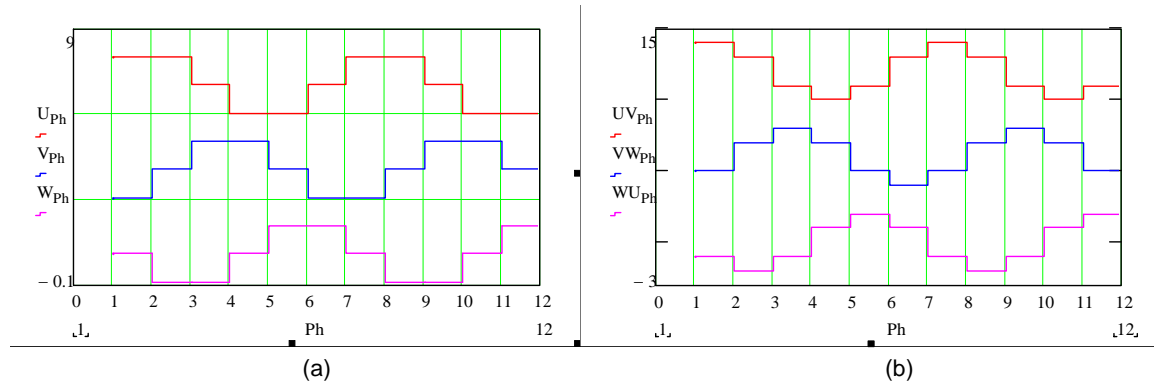

Figure 6. PWM Phase Signals (a) and Motor Winding Voltages (b)

The driver stabilizes the driving torque or rotation speed to get stable motor operation. Demand mode is set by using DIP-switches, and a new mode is activated only after a motor restart. When torque stabilization mode is selected, the duty cycle is stabilized via a PWM clock frequency adjustment without changing the PWM compare value. The compare value is adjusted in this mode only when the preset speed is increased or decreased by pressing the “Speed Up” or “Speed Down” buttons, respectively. The correction is implemented based on the measurement results of the interval counter. This counter measures the duration of each phase in units of PWM clock frequency. The four control buttons are used to start or stop the motor and adjust the rotation speed or torque. There are 20 levels in speed stabilization mode and 14 levels in torque stabilization mode.

Rotation direction is changed using the standard approach of reverse driving and waiting during the phase sequence for two motor windings. By switching PSoC's internal hardware buses, users can change the phases' driving sequence. Be aware, phases that are waiting for instructions should be changed only in the firmware.

Interrupts from the sensor signal-processing unit are the foundation of the main loop program. When no interrupts occur within a predefined timeout, the cycle in which the motor starts is forcibly initiated. The phases then start rotor rotation from a stop condition or after motor overload. The phase switching returns to the conventional method when periodic interrupts from the rotor sensor signal-processing section are received. So when a rotation sensor signal is received, the phase drive signals are switched and the PWM timers reloaded.

When rotation speed stabilization mode is selected, the PWM clock frequency is fixed, but PWM compare values vary depending on the measured data from the interval counter. A proportional regulator with a first order IIR filter is used in both modes. The more advanced regulator types (PID for example) can easily be implemented in the firmware due to low CPU overheads in the current implementation. The ideal single-revolution rate of the regulator (in RPMs) is determined by the PWM clock divider value N_{cd} and PWM timer period, N_{pwm} :

$$n = \frac{5}{2} \frac{F_{vc1}}{N_{pwm} \cdot N_d}, \quad (1)$$

F_{vc1} is the VC1 clock frequency. N_{pwm} is the PWM timers' period. N_d is the PWM clock divider coefficient.

The timer PWM H-, M-, and L levels are calculated using the speed coefficient, K_{speed} , with the following formulas:

$$\begin{aligned} H &= N_{pwm} K_{speed}, \\ M &= \frac{N_{pwm}}{2}, \\ L &= N_{pwm} - H \end{aligned} \quad (2)$$

The speed coefficient is set using the “Speed Up” and “Speed Down” buttons.

Conclusion

This note demonstrates using PSoC for brushless DC motor control. This design can be adapted for other rotor position sensing techniques, such as quadrature decoders and inductance-based position sensors. The driver can be updated to support motors with different power levels by replacing the coil driver.

References

1. “Handbook of Small Electric Motors,” William H. Yeadon, Alan W. Yeadon, McGraw-Hill, 2001.

Appendix A. Software Flowcharts

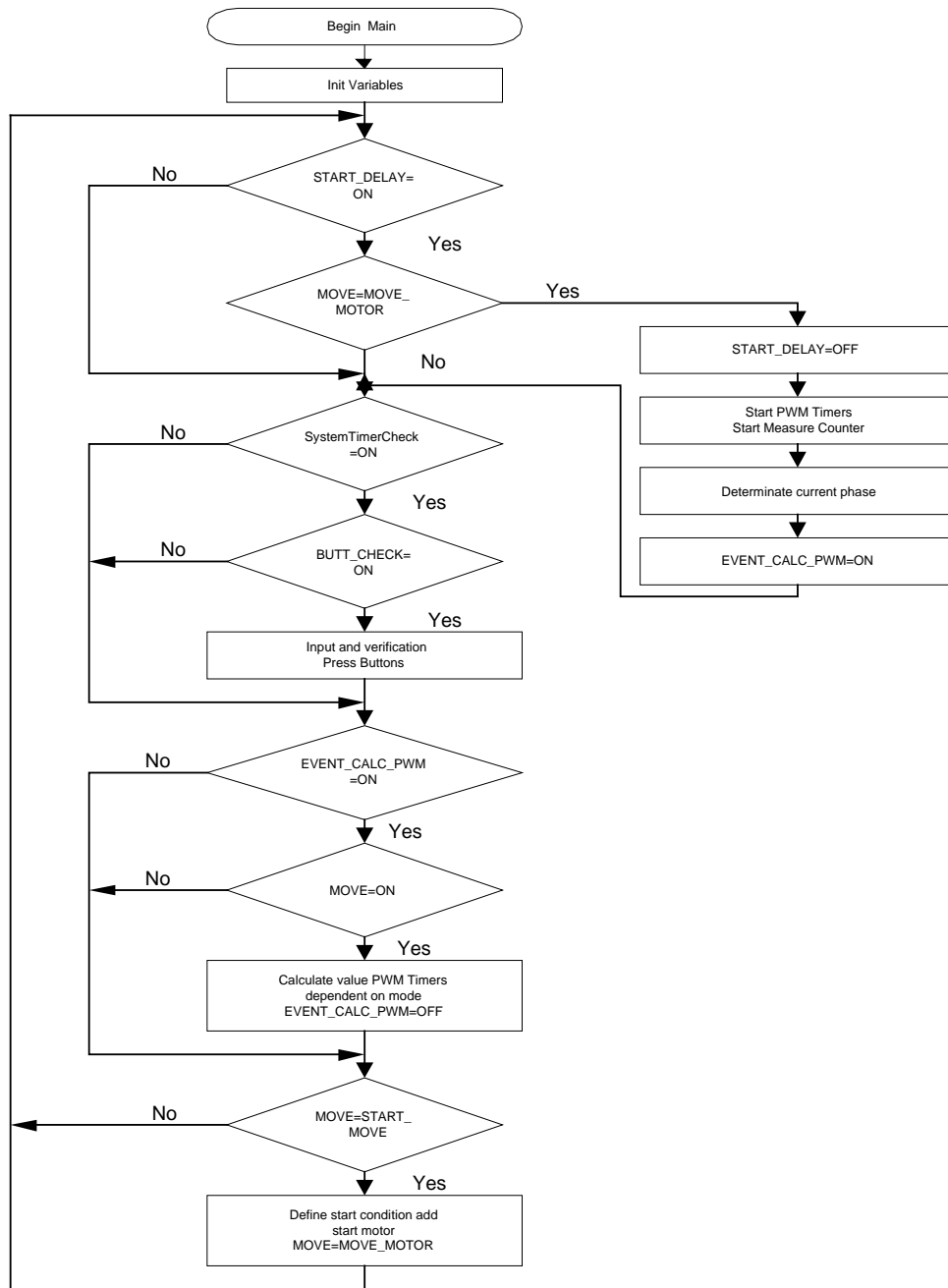

Figure 7. Main Loop Flowchart

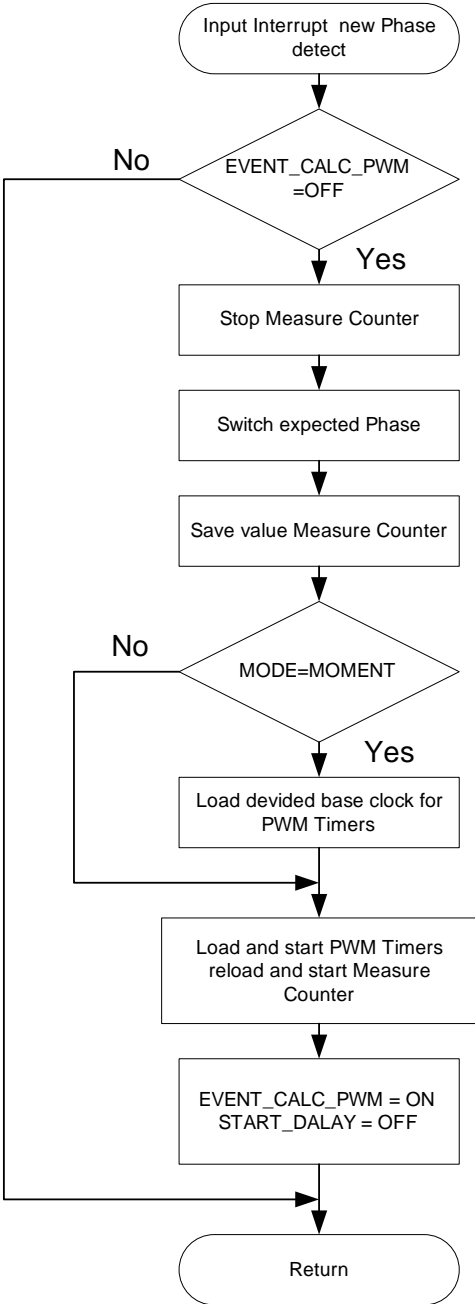
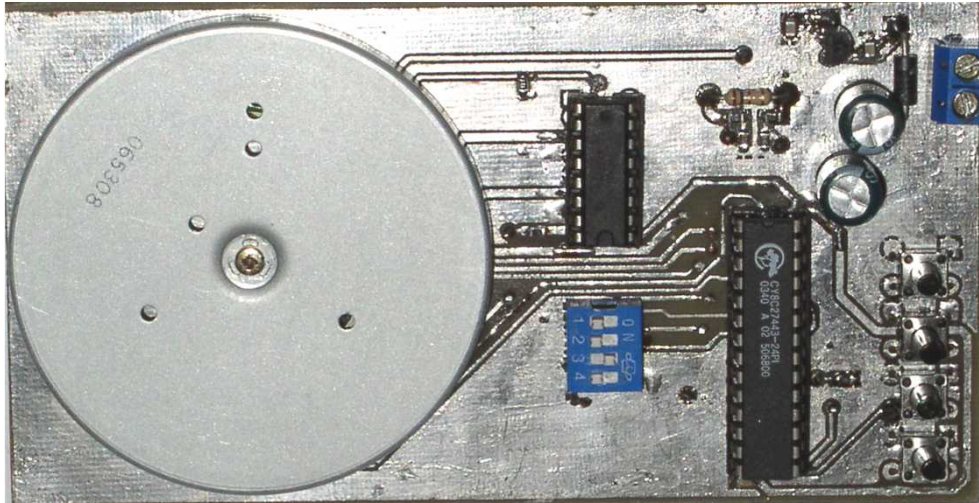

Figure 8. Sensor Comparator Interrupt Flowchart

Appendix B. Driver Photographs



(a)



(b)

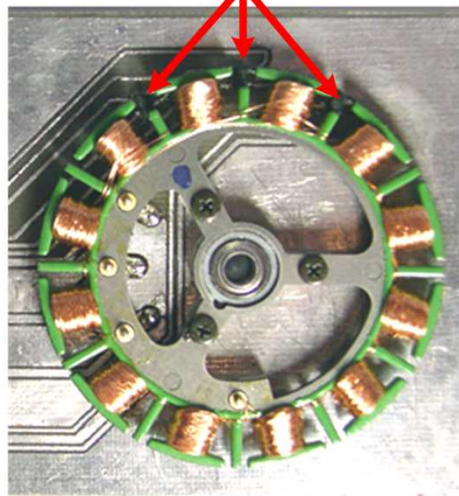

(c)

Figure 9. Driver Motor, Assembled Board (a), Rotor Opposite Side (b), Coils and Hall Sensors (c)

About the Author

Name: Andrey Magarita

Title: Sr. Application Engineer

Background: Andrey has more than 15 years experience in embedded systems design.

Contact: You may contact him at makar@lf.lviv.net.

Cypress MicroSystems, Inc.
2700 162nd Street SW, Building D
Lynnwood, WA 98037
Phone: 800.669.0557
Fax: 425.787.4641

<http://www.cypress.com/> / <http://www.cypress.com/support/mysupport.cfm>

Copyright © 2004 Cypress MicroSystems, Inc. All rights reserved.

PSoC™, Programmable System-on-Chip™, and PSoC Designer™ are trademarks of Cypress MicroSystems, Inc.

All other trademarks or registered trademarks referenced herein are the property of their respective owners.

The information contained herein is subject to change without notice. Made in the U.S.A.