

## Smart Smoke Detector

**Author:** Andrey Magarita  
**Associated Project:** Yes  
**Associated Part Family:** CY8C24xxxA, CY8C27xxx  
**PSoC Designer Version:** 4.2

### Abstract

This Application Note demonstrates use of a PSoC™ device as a smart smoke detector. A smoke detector as part of fire alarm system is explored.

### Introduction

Modern fire alarm systems use electronic smoke detectors to detect fire. According to the international safety standards, each home, office or industrial room must be equipped with a smoke detector. Most fire alert systems use smoke detection to judge the presence of fire. There are two types of smoke detectors: ionization and photoelectric. Both are described in detail as follows.

### Ionization

The ionization smoke detector has a small amount of radioactive material (for example, Americium 241, which emits the  $\alpha$ -particles) that ionizes the air in the sensing chamber. This renders conductive air and permits a current flow through the air between two charged electrodes. This also gives the sensing chamber effective electrical conductance. When smoke particles enter the ionization area, they decrease the conductance of air by attaching to the ionized air particles. This reduction in conductance can be compared to a reference value and by disagreement an alarm is activated. See Figure 1, which shows ionization type smoke detector operation.

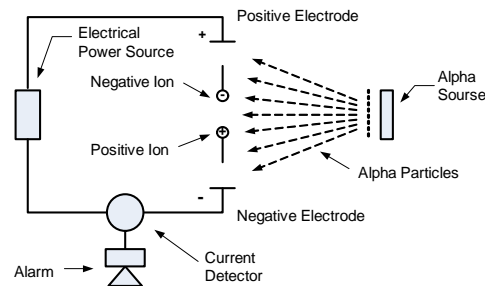
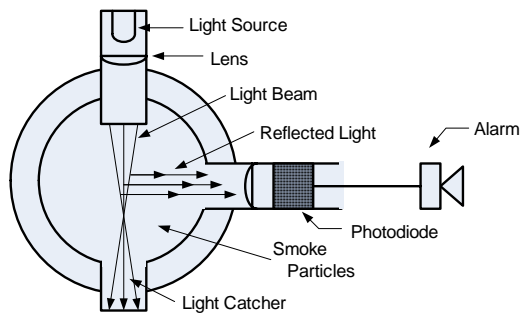

Figure 1. Ionization Smoke Detector

### Photoelectric

Photoelectric smoke detectors use the principle of scattered or reflected light to indicate the presence of visual smoke. When there's no smoke, the chamber is dark. The light shines across the chamber and is received in a light trap on the far side. When smoke is present in the chamber, a photocell, located at a right angle to the light source, senses the light scattered off the smoke particles and at a certain level of illumination, triggers the alarm sound or sends a signal to the central office module (Figure 2).



**Figure 2. Photoelectric Smoke Detector**

These two types of smoke detectors use different detection principles. Their response time is dependent on what types of materials are burning. The characteristics of an ionization detector make it more suitable for detection of fast flaming fires that are characterized by combustion particles the size of 0.01 to 0.4 micron range. Photoelectric smoke detectors are better suited to detect slow smoldering fires that are characterized by particulates the size of 0.4 to 10.0 micron range. Each type of detector can detect both types of fires, but their respective response times will vary, depending on the type of fire. Note that the sensitivity of photoelectric detectors degrades when detecting dark smoke particles (for example, burning rubber) due to a low light scattering ratio.

When the ionization and photoelectric detector chambers become contaminated over time, the result is a more sensitive detector. Although this may sound like a good thing, it is not and will most likely lead to numerous false alarms. As smoke or additional contaminants collect inside the ionization chamber, the headroom between the normal chamber background value and the alarm threshold value is decreased. The result is that, as time goes by, a very small amount of smoke or contaminates can trigger an alarm or cause an alert (pre-alarm) condition.

Intelligent fire panels have special algorithms that can compensate for this slow increase in detector background level. An indicator is also displayed on the fire panel (if networked equipped) indicating when a specific detector has a high chamber value, and should be checked, cleaned, and/or replaced immediately. Therefore, if the fire panel supports receiving information from a separate detector, customers can remotely check the state of each individual detector. This is accomplished only when networked detectors are used.

When a conventional non-networked detector is used (that has only relay output, signaling the fire alert), it should be equipped by a special test button to initiate the manual chamber testing procedure. The user needs to check detector operation by periodically pressing this button, for example, once per month. During this test, the response of an empty chamber is measured and the level is compared to upper and lower thresholds. When the signal response is too low, the light source or photo-receiver is either broken or very dirty. When the signal response is too high, the chamber is slightly contaminated and need to be cleaned.

The proposed smoke detector uses the photoelectric detection principle and provides a multi-level smoke presence indicator and an automatic smoke chamber self-test during start up or user initiation. The device allows modifications for different designs of smoke chambers and their sensitivity, and supports various LED and photodiodes. It has very low current consumption and noise suppression features.

An infrared photodiode and a light emitting diode are used as sensing elements in the chamber. The chamber design does not allow external light to penetrate the inside. The photodiode light is activated using an LED. The LED is positioned at an angle from the photodiode so that its directional light pattern does not intersect with the sensitivity region of the photodiode. The internal reflection from the interior chamber is minimal due to the unique chamber design. With these conditions, only a small amount of LED light can reach the photodiode when smoke is not present. As a result, the chamber side reflection ratio is very low.

When smoke (or a similar substance that is able to scatter the light beam) enters the chamber, the LED beam reflects light from the smoke particles and part of this reflection reaches the photodiode. The photodiode signal is amplified and measured by a detector. Smoke sensitivity depends on many factors including camera design, photodiode and LED type and their operating modes. This application examines two types of chambers with large and small volumes that reflect different sensitive element characteristics. The unique architecture of the PSoC device allows use of different cameras without any electric circuit change. Setup can be performed by changing hardware settings and threshold values inside the PSoC device without having to modify schematic/component values. PSoC also can support multiple detector features without design modification

## Smoke Detector Flowchart

The smoke detector flowchart is shown in Figure 3. At five-second intervals, the LED receives current pulses of approximately 100 microseconds. Part of the LED reflection beam touches the photodiode, which creates an electric current that is translated to voltage on a high-resistance resistor. The AC part of this voltage through a differentiating circuit (intended to cut the DC component) is fed to the programmable gain amplifier (PGA). After passing through a PGA, an amplified signal is fed to a band-pass filter (BPF) with a gain of about 17 dB. This filter amplifies and filters only friendly signals and removes the DC component that appears as a result of the PGA offset voltage amplification. The signal combination of the PGA and BPF allows a total stable system gain of approximately 55 dB, which supports chambers with low sensitivity. The PGA/filter settings were successfully tested on ten different CY8C24423A samples and demonstrated consistent repeatability and stability. Therefore, the PSoC device can deliver a total of 55 dB gain without problems. Note that higher gain only is required to support the test chamber function, when no smoke is reflected, and the signal is received and analyzed. Under normal smoke detection conditions, total gain is reduced and the signal from the second PGA is sampled by the ADC.

The following process of 8-bit ADC data stream is implemented in the firmware. If the first threshold level is reached, the device begins brightly blinking the LED and adjusts the sensitivity level by changing the PGA gain. Moreover, the detector reduces the measurement interval from 5s to 2s. If a second threshold level is reached, the device begins the time interval to turn on the alert signal and measure each second. If during this second threshold, the level still remains high, a solid-state relay is switched and an alarm line is opened, signaling that the system is reaching an alarm situation. The test is repeated up to three times and the chamber response is averaged to rule out false readings.

The BPF and Delta Sigma ADC provide noise immunity. The BPF reduces the noise level by limiting the input signal frequency spectrum and integrating a Delta Sigma noise signal filter. The influence of temperature on voltage bias drift and voltage reference change is eliminated as well by using the correlated double sampling technique. Voltage measurement of the smoke level channel is performed before the current pulse is fed to the LED and followed by estimating the offset value. This offset value is subtracted from the LED signal value while the level of scattered light is being estimated.

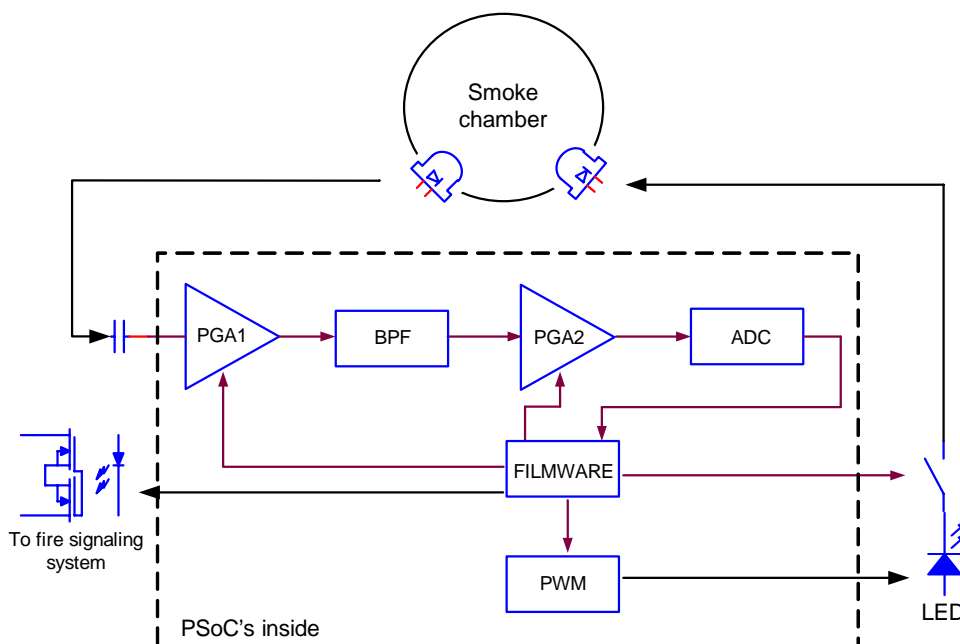

Figure 3. Smoke Detector Flowchart

### Device Schematic

The device schematic is shown in Figure 4. In today's market, much attention is focused on minimizing power consumption of smoke detectors. In this application, some methods are used to achieve this. First, the device sleep mode is used in standby state. In this state, analog and digital modules are switched off. The device's active work time is decreased to a minimum of 1.2 ms during 5s sleep intervals. The current impulse duration of the LED is decreased to 100  $\mu$ s. The analog modules are switched on only during measurement and threshold level detection. The device uses the linear regulator with separate power consumption and the input voltage is supplied through limited 1 kilohm resistance. After the analog modules are turned on, the active work time is set by estimating the duration of the transient process in a photodiode amplification channel.

The threshold measurement level is defined by the local requirements for fire alarm detection and can easily be adjusted. The linear regulator reduces power supply to 5V (a 3.3V reduction does not significantly reduce system consumption). The duration of the LED current pulse is limited by the minimum BPF filter setup time and the ADC conversion time.

The chamber's LED pulse current should be not less than 300 mA (this is true for chambers embodied in this design). Since this pulse current does not produce high consumption from the linear regulator, the limiting resistor R9 is used in the supply path for noise reduction. The LED pulse current accumulates energy in the C7 capacitor, which is later charged via R9 following 1s. This arrangement allows an average consumption in standby state of about 20-25  $\mu$ A and a peak current in standby state that does not exceed 170  $\mu$ A. For peak current limitations, resistance R7 is used and stay time in sleep mode between active working phases does not exceed 2s. This time is necessary for full capacitor C4 charging in the device supply circuit. Moreover, after power up and the configuration is loaded, the device goes into sleep mode. For 2s the full filter C4 and C7 capacitors are charging. The detector supply current is shown in Figure 5. During normal operation, as can easily be seen, the sleep current is about 10  $\mu$ A. The LED is blinks for a very short time (pulse duration is about 100 $\mu$ s) during normal operation, signaling each threshold-measuring event. The nominal measurement period is set to 5s.

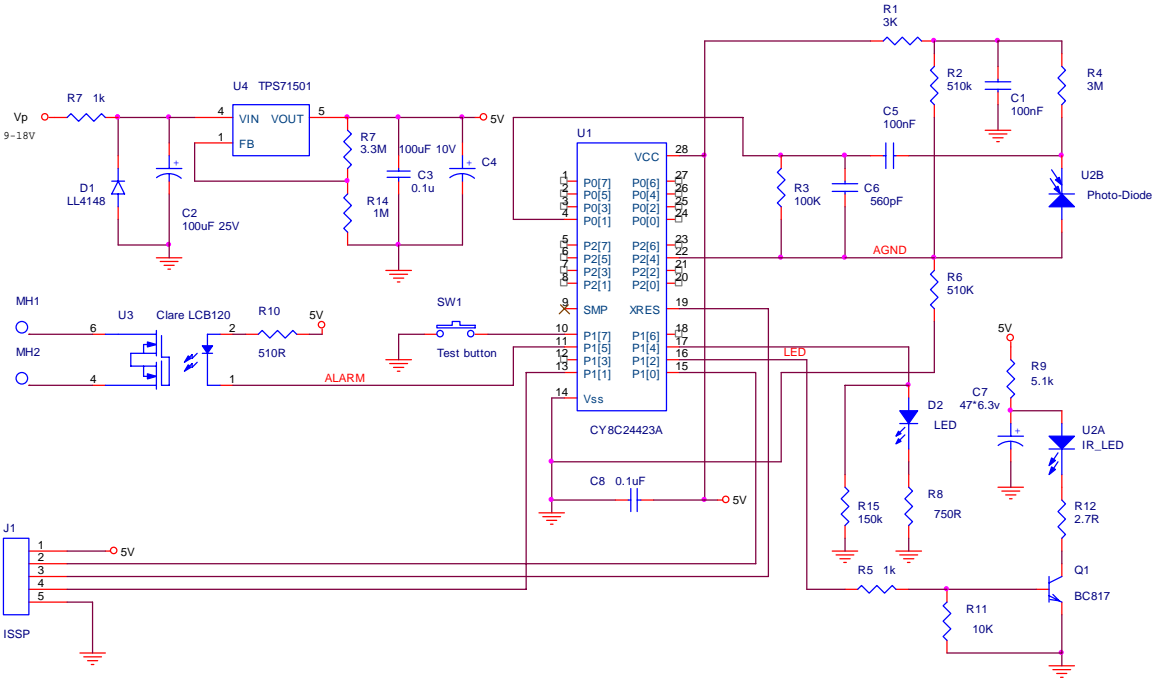

Figure 4. Detector Schematics

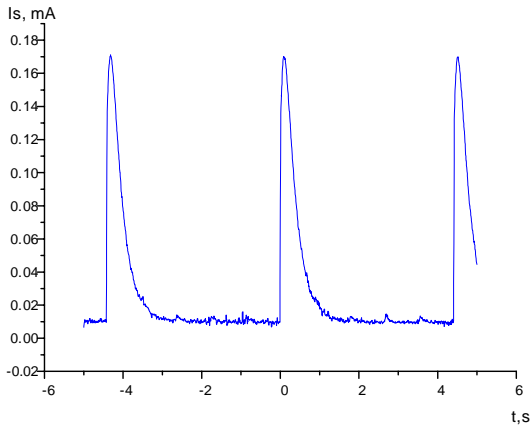

Figure 5. Power Supply Current Time Graph

The normally closed optically isolated solid-state relay, manufactured by Clare as Type-1B, is used as a galvanic alarm signaling control circuit. When the alarm condition is true, the relay breaks the signaling line. The chambers from existing smoke detectors were used in this design (see Figure 10 in Appendix C). The detector can be supplemented with a temperature measurement circuit without noticeable modifications by adding a thermistor and an additional bias resistor. Temperature measurement is required by fire security standards in some countries.

### PSoC Internal Placements

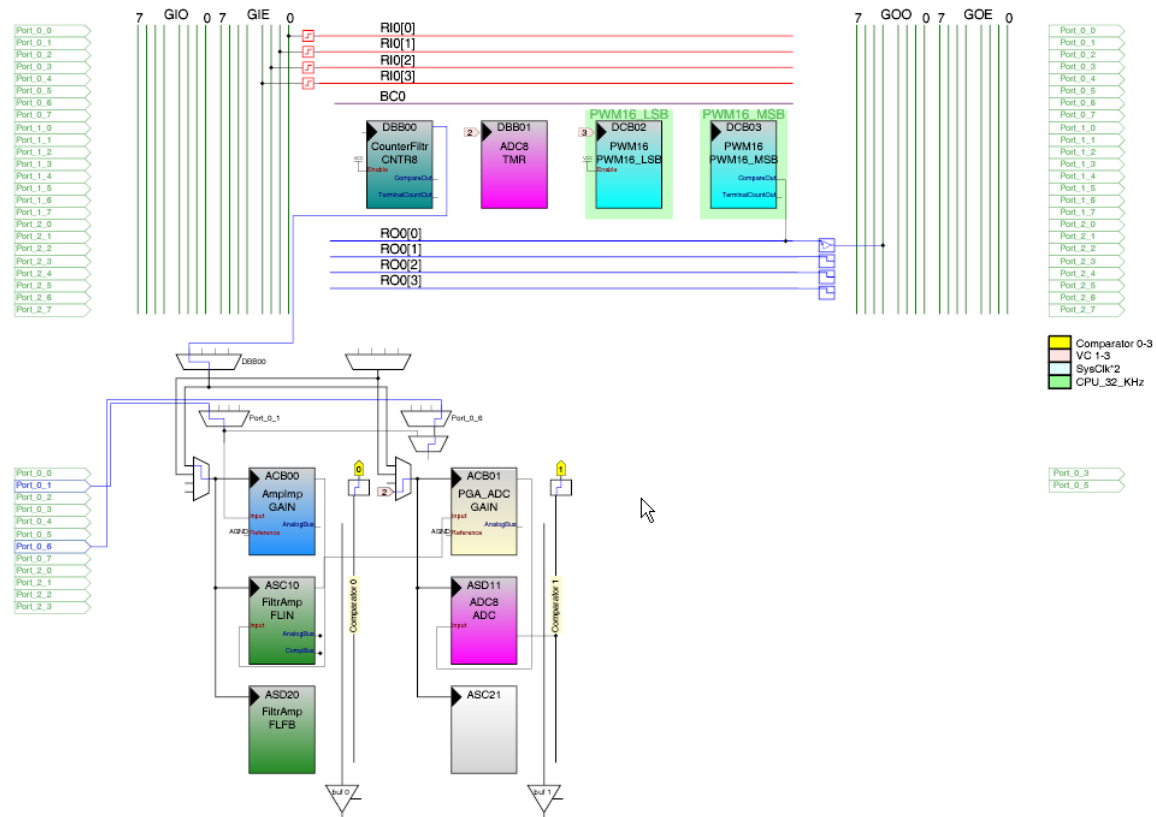

Figure 6. PSoC User Module Placement

User module placement is shown in Figure 6. DBB00, a clock source for the filter, can be eliminated by setting VC1=4 and VC2=5 (if you need one free digital block). DBB01 is an ADC timer. DCB02 to DCB03 are 16-bit PWMs used to set LED brightness and some service functions.

You can use an 8-bit PWM with little code modification if you need another digital block for other purposes. These blocks can be useful if you want to deliver an address (networked) smoke detector, where communication protocol needs to be supported. This design is under current development.

## Conclusion

This Application Note describes a smart smoke detector with multi-level detection capabilities. The detector can cover worldwide fire system standards, including networked operation support, with minimal modifications. About half the Flash memory is free and can be used for various purposes.

## References

1. Moore, W. D., "Automatic Fire Detectors," Fire Protection Handbook, 17th Ed., National Fire Protection Association, Quincy, MA, 1991.
2. Burry, P., "The Principles of Fire Detection - Ionization Chamber Smoke Detectors," Fire Surveyor, April 1982, p. 20
3. <http://www.interfire.org/features/smokedetector.asp>
4. <http://www.sas.org/tcs/weeklyIssues/2004-07-23/feature1/>

## About the Author

**Name:** Andrey Magarita

**Title:** Sr. Application Engineer

**Background:** Andrey graduated from National University "Lvivska Polytechnika" (Lviv, Ukraine) in 1989 and is presently working as Senior Application Engineer for Zuvs, a private company. He has more than 15 years experience with embedded systems design.

**Contact:** You can contact him at

[makar@lft.lviv.net](mailto:makar@lft.lviv.net)

### Appendix A: Software Flowcharts

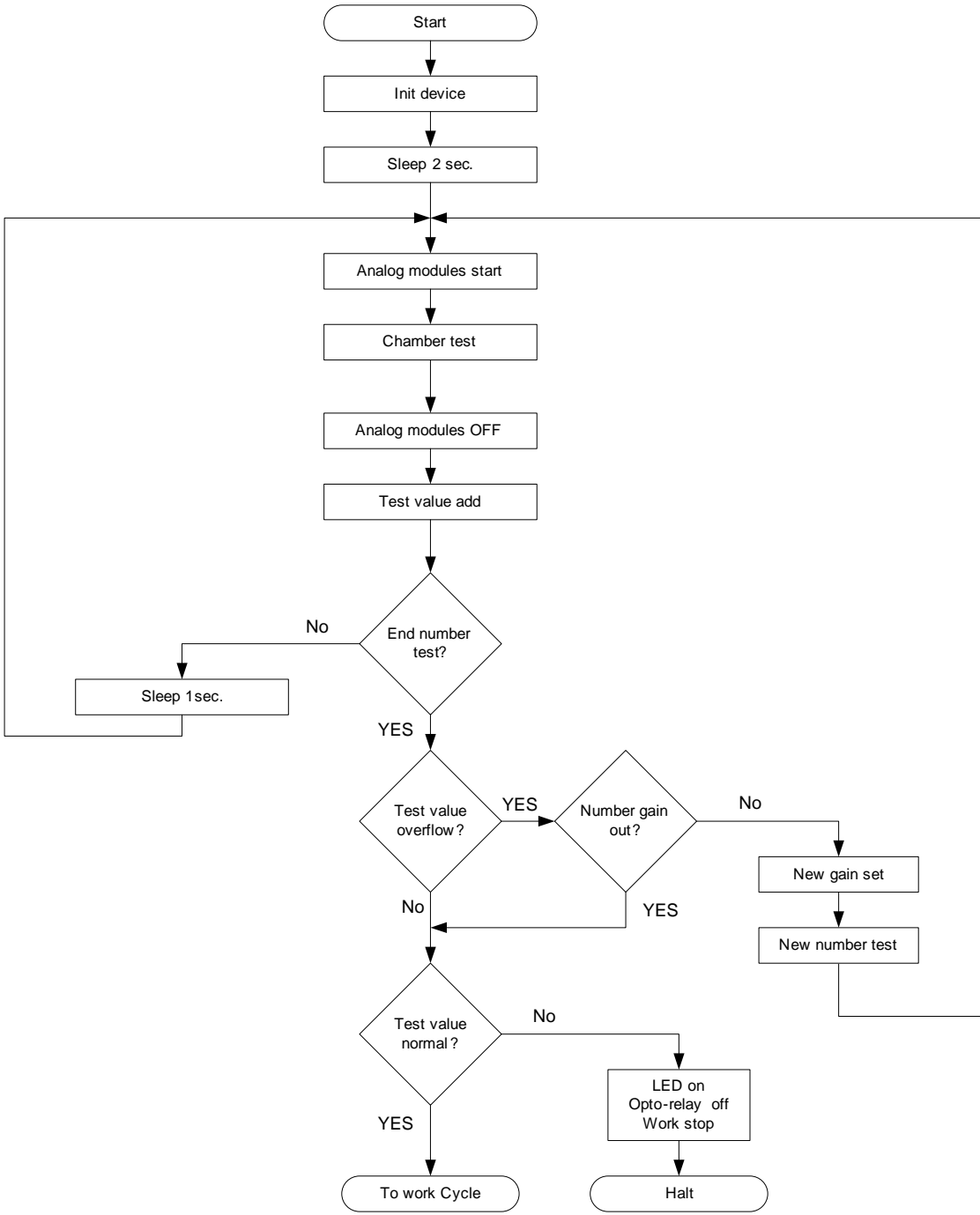

Figure 7. Boot Procedure

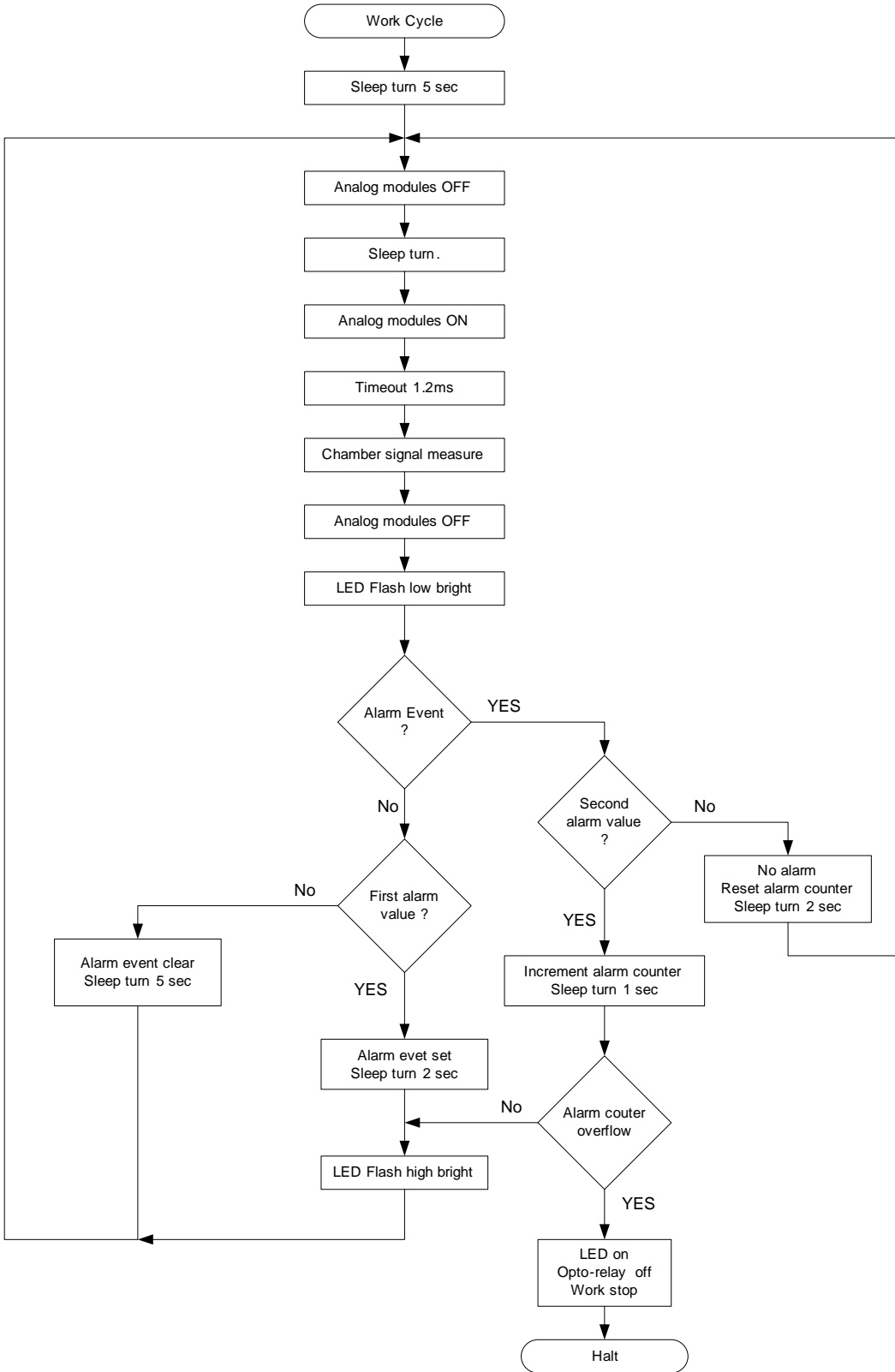
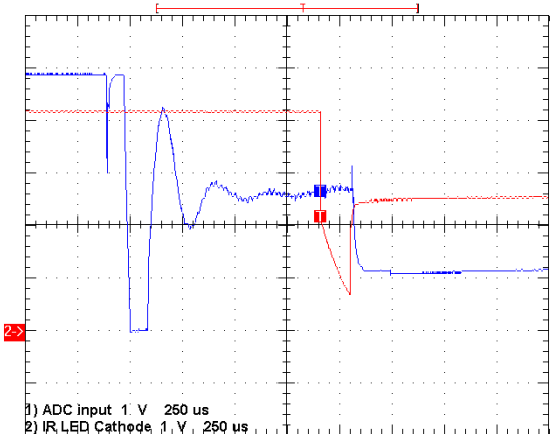
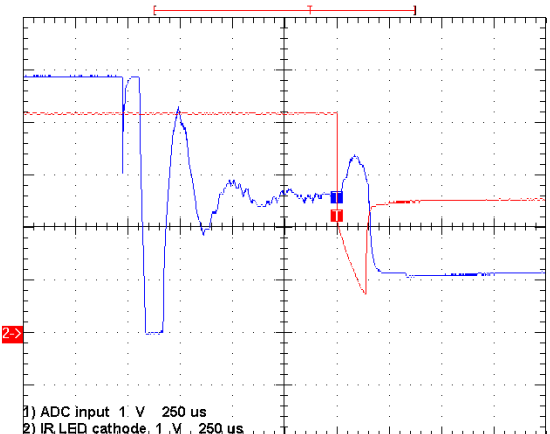

Figure 8. Main Operation Procedure

### Appendix B: Detection Waveforms for Various Smoke Levels



No smoke



Low smoke level

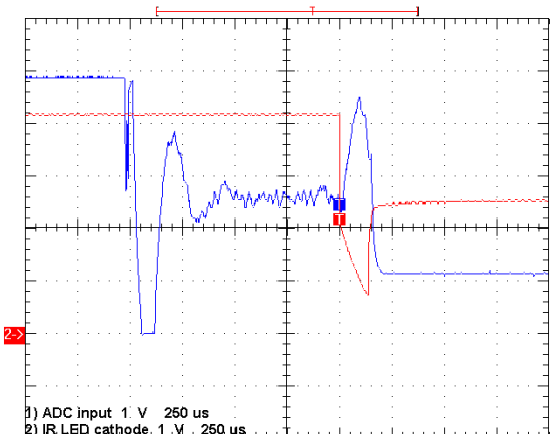

High smoke level

Figure 9. Waveforms on IR LED Cathode (Red) and ADC Input (Blue) for Different Smoke Concentrations Inside Chamber

## Appendix C: Detector Photographs



Figure 10. Internal Construction of Smoke Chamber



Figure 11. Two Detectors with Different Chamber Sizes and Different Chamber LED and Photodiodes

---

Cypress Semiconductor  
2700 162<sup>nd</sup> Street SW, Building D  
Lynnwood, WA 98037  
Phone: 800.669.0557  
Fax: 425.787.4641

<http://www.cypress.com/> / <http://www.cypress.com/support/mysupport.cfm>

Copyright © 2005 Cypress Semiconductor Corp. All rights reserved.

PSoC™, Programmable System-on-Chip™, and PSoC Designer™ are PSoC-related trademarks of Cypress.

All other trademarks or registered trademarks referenced herein are the property of their respective owners.

The information contained herein is subject to change without notice. Made in the U.S.A.