



Application Note

AN2291

Ultrasonic Vehicle Parking Assistant with LIN 2.0 Interface

Author: Valeriy Kyrynyuk
Associated Project: Yes
Associated Part Family: CY8C27443
PSoC Designer Version: 4.2
Associated Application Notes: No

Abstract

This Application Note describes a multi-channel, ultrasonic system for vehicle parking assistant applications. Also included in this design are a LIN slave interface and an example LIN master interface for communication between the application and the vehicle network.

Introduction

Parking assistant vehicle features are appearing on many of today's vehicles. The parking assistant provides increased safety especially in large cities. Moreover, LIN Bus 2.0 is now a widely implemented vehicle communication network. Popular LIN bus-connected applications include window lift control, mirror control, seat control, lighting control, parking assistant, instrumentation/gauge control, and other various vehicle sensors. The main purpose of LIN-based devices is to simplify design and eliminate more expensive CAN nodes for non-critical, low-speed tasks. This Application Note includes an 8-channel, vehicle parking assistant integrated into the vehicle LIN bus. The parking assistant (LIN slave) senses an obstacle then provides an alarm according to the obstacle's distance. Modern safety expectations and driver convenience, along with parking conditions and increased vehicle size are driving the popularity of this application.

About the Parking Assistant

The main task of the parking assistant device is to track the obstacles that appear in front of, or behind, a moving vehicle. The assistant must inform the driver of the distance to the obstacle and switch on a sound alarm when the distance is dangerously close.

Obstacles can be pedestrians, buildings, other vehicles, and mechanical constructions. Ultrasonic sensors are the most popular sensor for this application. Sensors of this type are reliable, can resist contamination, and are low in cost. In this Application Note, ultrasonic sensors MA40FF14-1CN from [Murata Manufacturing Co., Ltd.](http://www.murata.com) are used. Listed below are key features of this sensor:

- Ultrasonic resonator frequency: 40 kHz
- Maximum voltage $V_{\text{peak-to-peak}}$: 160V
- Sound beam pattern into horizontal plane: 110 deg
- Sound beam pattern into vertical plane: 45 deg
- Minimum distance to obstacle that can be detected: 30 cm (1 foot)

The maximum distance to an obstacle that can be detected by the parking assistant depends on shape, position, material of the obstacle, and electrical schematic design. Implementation in this application detects obstacles as distant as 2.5m (8 feet).

It is important to understand the principle of ultrasonic sensor operation. The resonator emits short ultrasonic pulses (0.4 ms) and receives the reflected signal. The transient period of resonator fading is 1.5-1.8 ms. This is the primary limiting factor with regard to minimum distance detection. The included electronic control pulse generator excites the resonator and performs signal processing. The time between pulse ejection and detection of a reflected signal is used to calculate the distance to an obstacle. See Equation (1):

$$l = \frac{v \cdot t}{2} \quad (1)$$

l is the distance to the obstacle. v is the speed of the sound wave. t is the time between pulse ejection and the detection of the reflected signal.

The speed of the sound wave depends upon several factors, which include temperature, density, and air composition. The sound wave speed is illustrated in Laplace's formula:

$$v = \sqrt{\gamma \frac{RT}{\mu}} \quad (2)$$

γ is the adiabatic constant. R is the absolute gas constant. T is the air temperature in kelvin unit. μ is the molecular gas weight. Typically, Equation (2) is simplified into Equation (3), which only takes into account air temperature:

$$v = 20.046\sqrt{T} \quad (3)$$

The nominal speed of the sound wave at 10°C is near 335 m/s. In this Application Note, the influence of temperature on sound wave speed is not taken into account. But this influence can easily be included in the calculations within this design. The relative accuracy of determining the distance for this project is about 7.5% (given the air temperature is within a range of -20°C to +40°C). Such precision is typical for parking assistant devices. Performance can be improved with design enhancements.

The parking assistant consists of several (up to 8 for each front/rear module) ultrasonic sensors. A typical implementation is shown in Figure 1 and Figure 2 (horizontal and vertical operation scope area).

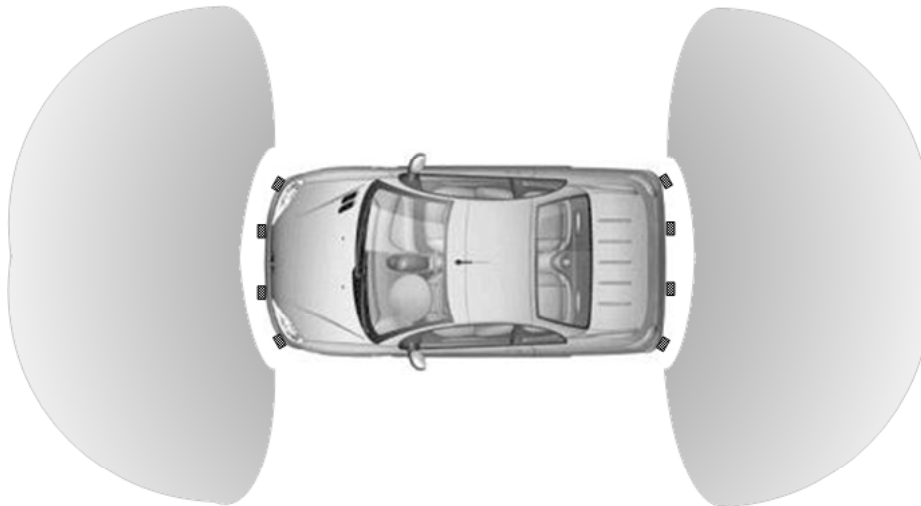

Figure 1. Sensor Placement and Scope Area. Top View



Figure 2. Sensor Placement And Scope Area. Side View

The sensors' quantity and exact locations may differ depending on vehicle dimensions, target system cost, accuracy requirements, and operation reliability demands. Usually, vehicles have two front/rear LIN slave parking assistant devices (Figure 3) that connect to a single LIN master. The LIN master can have its own display or be included on the vehicle navigation system display.

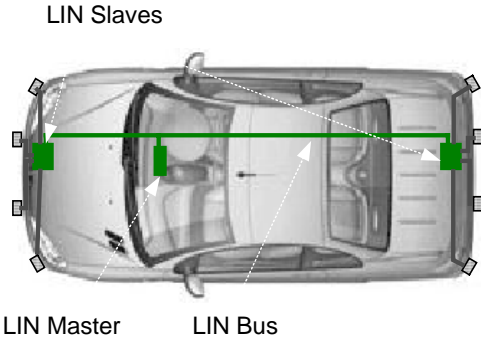

Figure 3. Parking Assistant Integrated into LIN Bus

Let's consider the implementation of the slave and master devices in this design.

Slave Device

When conventional microcontrollers (MCUs) are used for parking assistant applications, the resulting device flowchart is as shown in Figure 4. The device consists of the analog signal-processing circuit to excite the piezoelectric transducer and pre-amplify the reflected signal, 2 analog multiplexers, a programmable gain amplifier, and a band pass filter.

The device operates as follows: the counter is started and the 40 kHz generator emits a 0.4 ms pulse. This pulse comes to the 8-channel analog switch and ultimately drives the resonator excitation circuit. The resonator excitation circuit amplifies the pulse level from conventional microcontroller output levels to 160 V_{peak-to-peak}. The amplified pulse goes directly to the sensor and excites the piezoelectric transceiver. Note that this high-voltage signal is required because waterproof piezoelectric transceivers have low sensitivity and therefore demand large excitation voltages. The resonator emits the sound wave to the surrounding space, which becomes reflected by the obstacles. The reflected wave returns to the resonator, which converts it into a corresponding electrical pulse. The electrical pulse enters the 8-channel analog switch. The signal is then amplified and sent to a band pass filter. The filtered output level is checked by the threshold comparator.

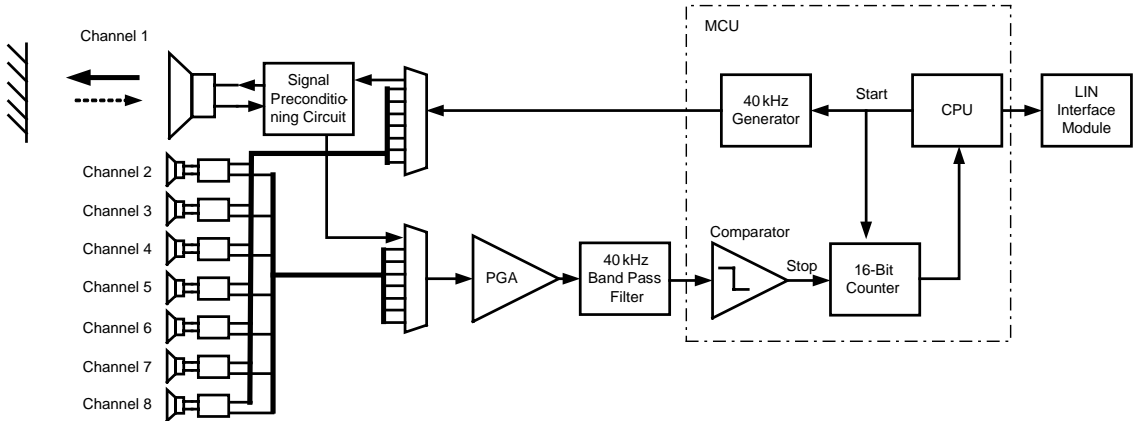

Figure 4. Flowchart of Parking Assistant Built Around Conventional MCU

Some existing parking assistant designs do not include the band pass filter. This has a distinctly negative impact on the system's immunity to noise. From the filter, the signal arrives at the comparator, which stops the counter and informs the MCU of signal receipt.

The disadvantage of the conventional-MCU approach in Figure 4 is the requirement of as many as four integrated circuits and additional passive and active components that increase system cost and reduce reliability of the end product.

The PSoC™ mixed-signal array provides better implementation thanks to moving-signal multiplexing, and the amplification and filtering functions.

The flowchart for PSoC-based implementation is shown in Figure 5.

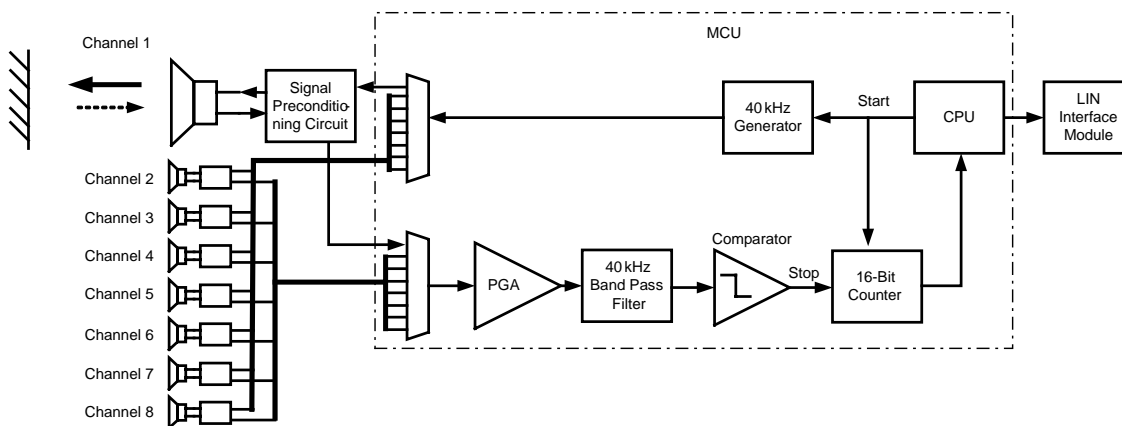

Figure 5. Flowchart of Parking Assistant Based on a PSoC Device

The PSoC device contains internal resources for 8-sensor input/output signal handling, amplifiers, band pass filters, and comparators with adjustable threshold levels. These on-chip resources sharply reduce total system cost.

The electrical schematic of the parking assistant slave device with 8 ultrasonic sensors and LIN interface is shown in Figure 6. The device is powered from the vehicle power network, which operates in the range of 9 to 16 volts. The slave includes a 5-V linear DC regulator, 8 signal-processing blocks for each ultrasound sensor channel, and the LIN Bus 2.0 transceiver based on the [Melexis TH8080](#) device. In order to reduce system cost, the quartz resonator is absent from the slave devices. Synchronization of the 40 kHz generator and LIN bus communication is provided through the interface of the LIN master. Communication speed is fixed at runtime.

The one-channel signal preconditioning circuit is shown in Figure 7. Resonator excitation in each channel is accomplished using the Q_1 transistor and the U_4 transformer. Q_1 is powered off of the vehicle battery from the filtered voltage bus.

The 160- V_{pp} signal appears on the secondary transformer winding. It is very important to tune the transformer core for maximum output voltage at the second transformer winding by identifying the LC circuit's resonance condition. The LC circuit is formed by the winding inductance and piezoelectric transceiver capacitance. When the circuit is tuned to resonance, the piezoelectric transceiver excitation pulse decay time is minimal, which allows for easy distinction between reflected signals and closely placed obstacles.

The reflected signal from the sensor is pre-amplified by the Q_2 transistor and centered around AGND by the $C_{12}R_8$ high pass filter. All ensuing signal processing is done inside the PSoC.

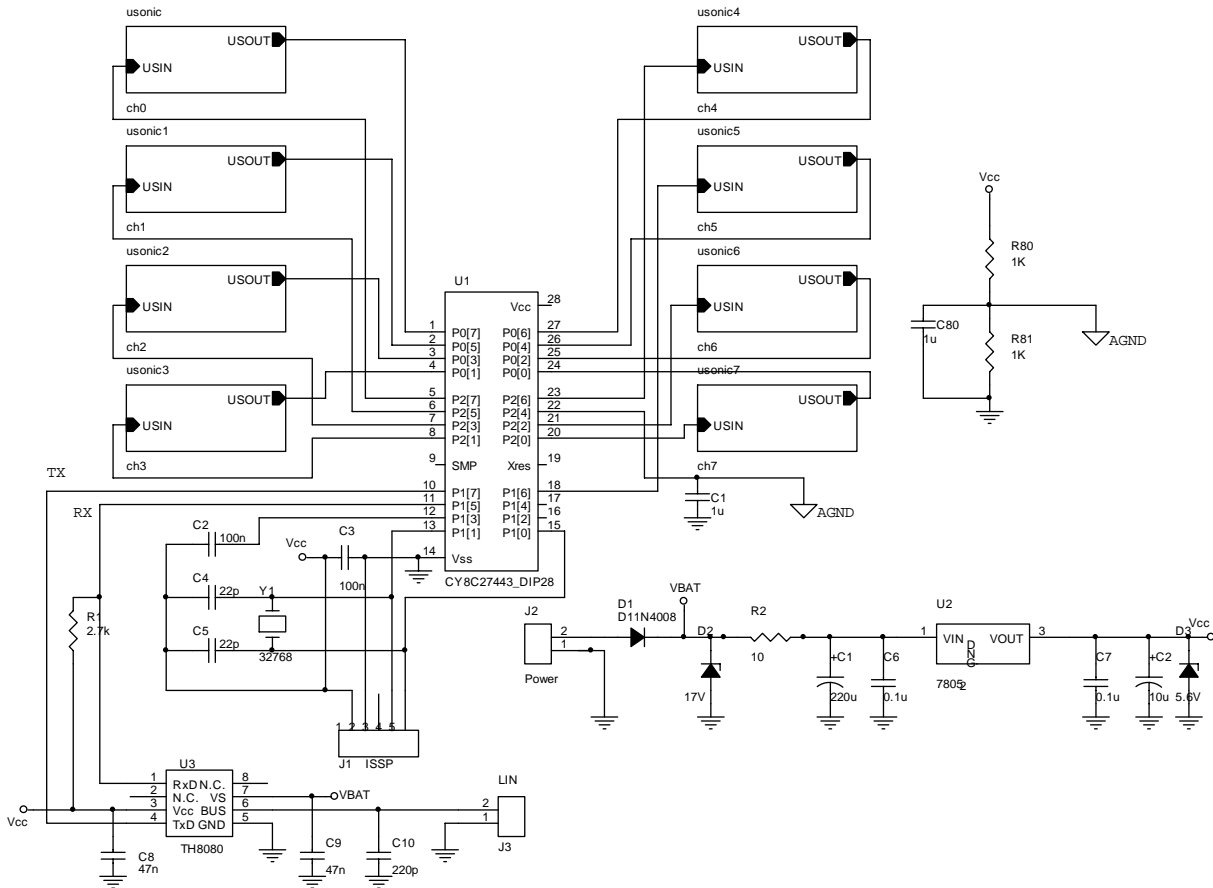

Figure 6. Schematic of Parking Assistant with LIN Slave

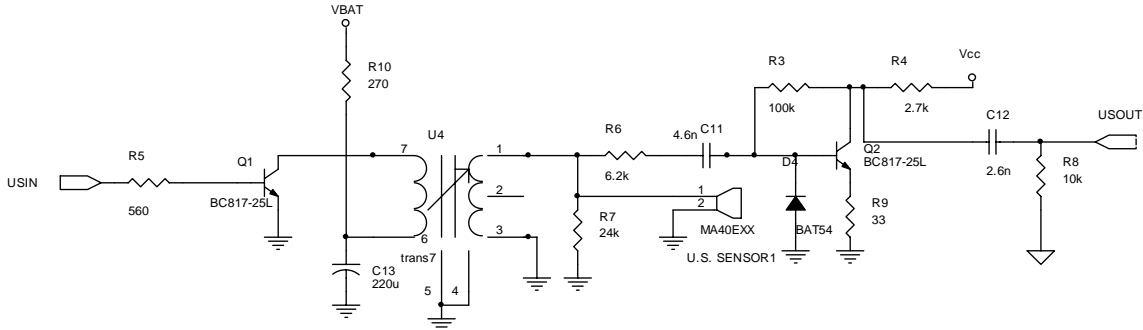

Figure 7. One-Channel Signal Preconditioning Circuit

Internal PSoC user module placement is shown in Figure 9. Note that the LIN interface is implemented using other loadable configurations.

A closer look at implementation shows a 40 kHz continuous generator (PWM) located on DBB00. A counter, located on DBB01, is used to control the sample pulse, sample tracking, and measurement duration for the response pulse.

All of these control functions are implemented inside an interrupt processing routine.

Sample pulse switching by commutation of a generator output to a different output row line is achieved by setting the appropriate bits of the global digital interconnect bus register. The reflected pulse signals have amplitude in the range of 5 to 100 mV (Figure 8).

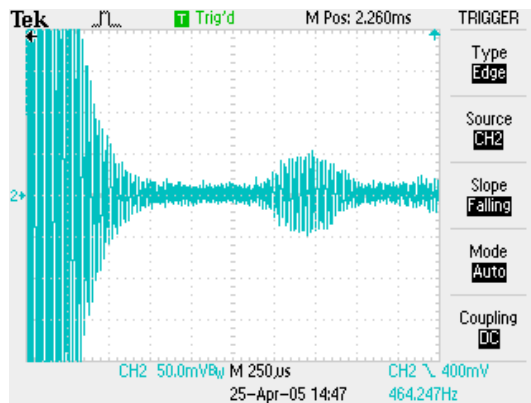

Figure 8. Reflected Signal from Ultrasonic Sensor

The separated and preliminarily processed signal is routed to the programmable gain amplifier on the ACB01 block. The amplified signal flows to the band pass filter for noise suppression to prevent a false comparator trigger. Following filter processing, the signal is detected by the programmable threshold comparator on ACB00. If the signal level is sufficient for comparator switching, then the Comparator Bus 0 interrupt is triggered. The interrupt service routine (ISR) captures the time value between emitted and reflected pulses. This is done by reading the contents of the Counter8_1 along with a software counter, which is incremented by the Counter8_1 ISR.

If the reflected signal amplitude drops proportionally to the distance square, it is a good idea to implement dynamic comparator threshold adjustment to get better device noise immunity. In this design, the comparator threshold reduces as expected obstacle distance increases, thereby proving better sensitivity to long-range signal reception. Table 1 illustrates this process.

Table 1. Comparator Threshold According to Response Time

Time ms	Distance m	Comparator Reference	Threshold V
1.6	0.268	0.5000	1.250
2.4	0.402	0.4375	1.094
3.2	0.536	0.3750	0.938
4	0.670	0.3125	0.781
4.8	0.804	0.2500	0.625
5.6	0.938	0.1875	0.469
6.4	1.072	0.1250	0.313
8.8	1.474	0.0625	0.156
16	2.680	0.0625	0.156

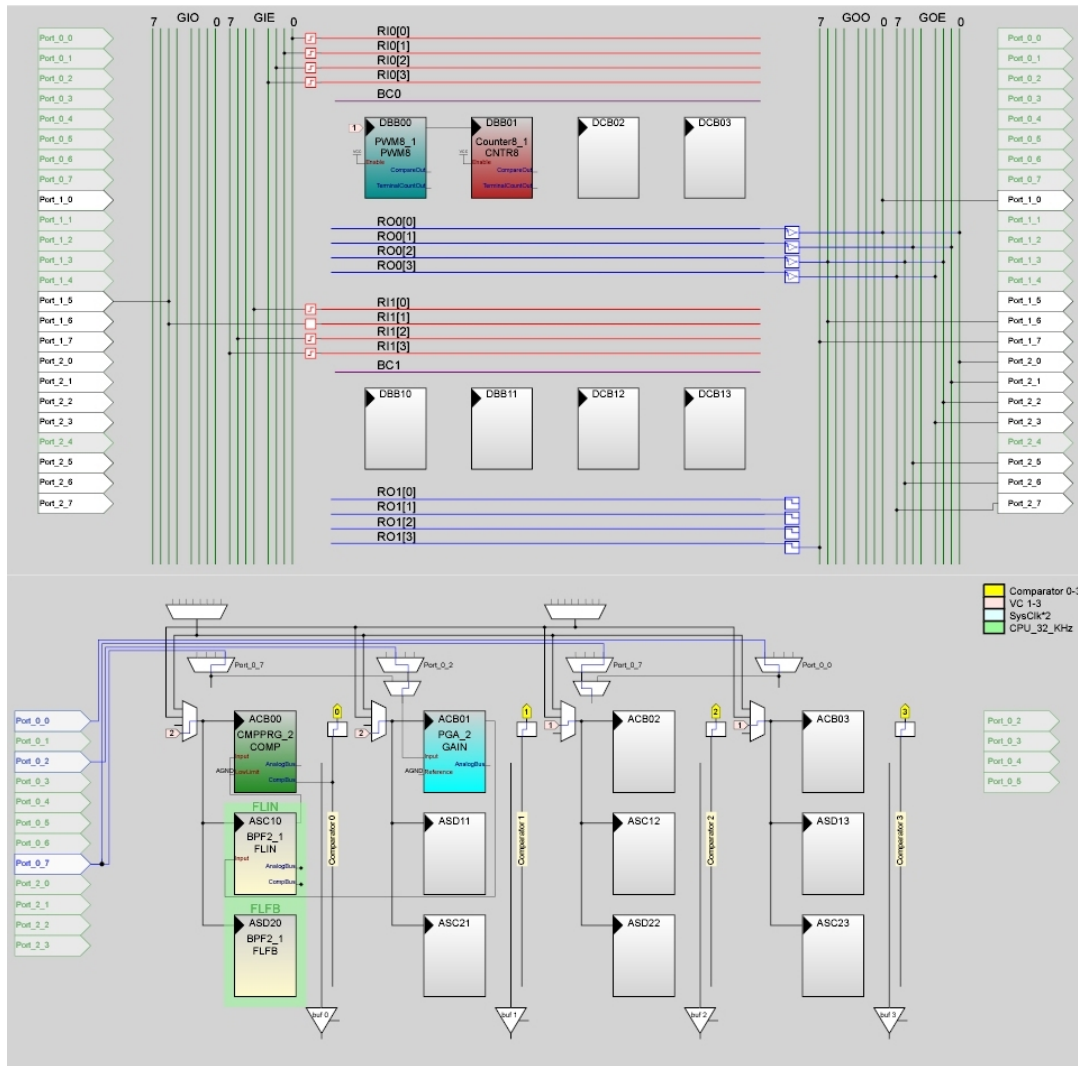

Figure 9. PSoC Internal User Module Configuration

The distance to an obstacle is defined in the program with the following equation:

$$d = \frac{55w_{Count}}{128} - 10 \quad (4)$$

d is the distance to an obstacle in centimeters. w_{Count} is the time in 0.025-ms increments. This equation was refined through empirical testing to take into account the piezoelectric resonator/filter's setup time. After the sampling process is completed, the distance is calculated and placed into an array. The program then begins the sampling on the next channel.

Detailed information about sampling periods is shown in Figure 10.

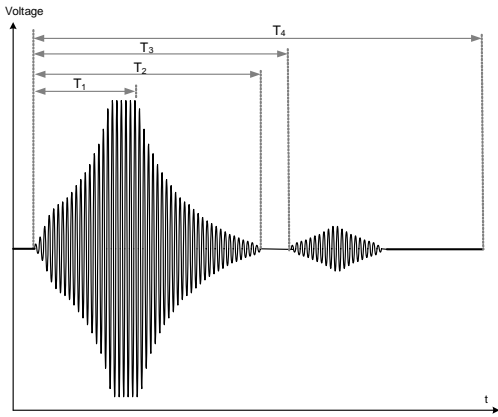

Figure 10. Sample Operation Periods

T₁ is the time of exciting pulse (0.4 ms). T₂ is the time of resonator's radiation (1.5-1.8 ms). T₃ is the time between the start of sampling and the receipt of the reflected signal. T₄ is the maximum time (16 ms).

Let's consider the sensor algorithm in detail. Two flowcharts are shown below: the main cycle and comparator interrupt handling flowchart (Figure 11) and the Counter8_1 interrupt handling flowchart (Figure 12), which controls pulse generation and comparator operation.

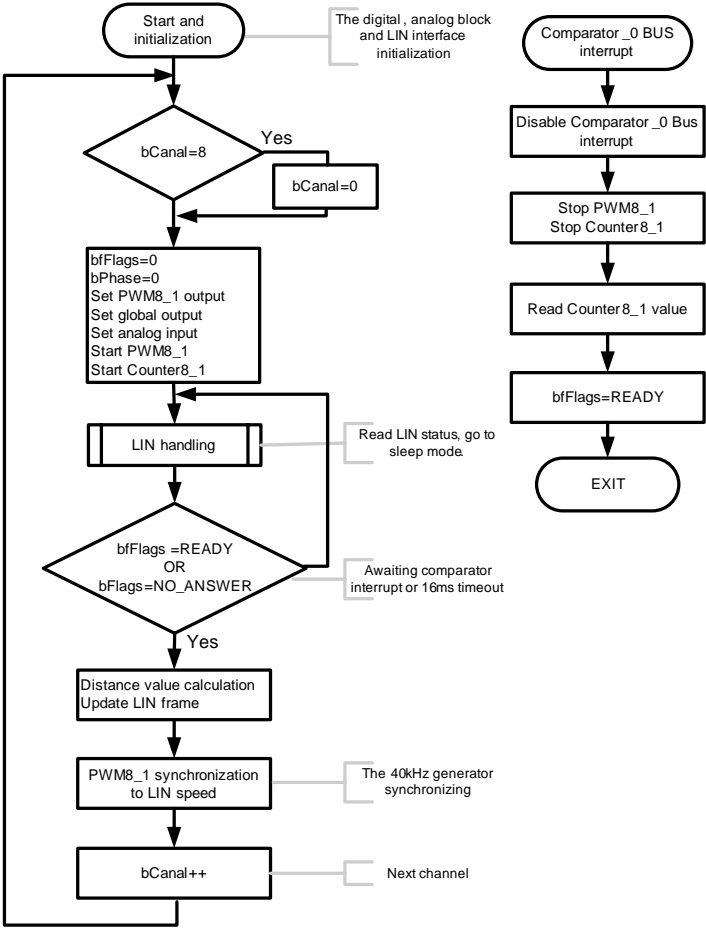

Figure 11. Main Cycle and Comparator Interrupt Handling Flowchart

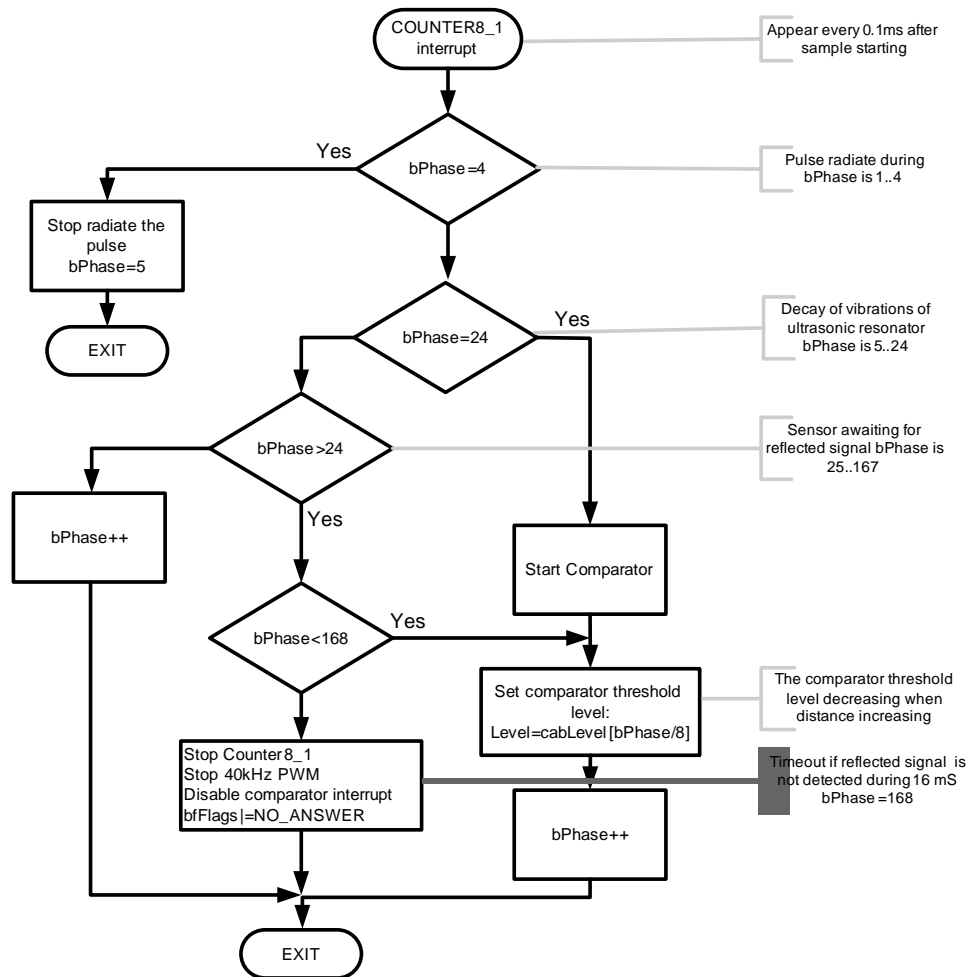

Figure 12. Counter Interrupt Handling Flowchart

LIN Slave Setup

The LIN 2 software module functions are not considered in this Application Note. This information is described in the [LIN Bus Reference Design Kit](#) documentation on cypress.com.

The parking assistant can easily be integrated with existing LIN bus communication. Only one message is used in this project for data communication regarding distance to obstacles. In this project, the settings of the LIN slave devices are:

- o NAD (node address for diagnostic): 01/02 (for different slave devices)
- o Message ID for reading distance values: 1002
- o Speed in bps: 19200

Frame properties of the LIN slave include:

- o Message ID: 1002
- o Direction: slave to master
- o Message Length: 8 bytes

Each byte in a frame is represented as distance from corresponding sensor in centimeters. The detectable range is from 30 to 255 centimeters.

It is possible to add additional frames, for instance, to remotely modify the comparator operation thresholds or add switches to the NAD setting.

Slave Device Photos

Figure 13 and Figure 14 show the parking assistant slave device PCB. The 4 channels (from 8 possible) are assembled on the board.



**Figure 13. Parking Assistant Slave Device
Top Side**

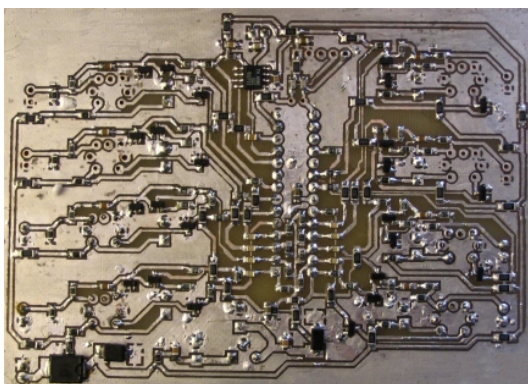

**Figure 14. Parking Assistant Slave Device
Bottom Side**

Master Device

The sole purpose of the LIN master is to communicate with the parking assistant LIN slaves to inform the driver of obstacle distances and generate warranted alarm signals.

The electrical schematic of the LIN master is shown in Figure 15. The device consists of two LED bar graphs (10 LEDs per line) to indicate the distance to an obstacle, a beeper for alarm sound, 5-V linear regulator, and a LIN bus communication module. Also included in the LIN bus master is a quartz resonator for synchronization of the PSoC communication clock. The master must hold communication speed steady as the LIN slave (the parking assistant) is synchronized to the communication interface. Pay special attention to the additional port pin P1[3], which is used to activate and inactivate the parking assistant devices. Active mode is represented by a high-level external signal. Inactive (sleep) mode is represented by a low-level signal. The parking assistant can be activated, for example, when the driver switches the transmission gear to park or reverse.

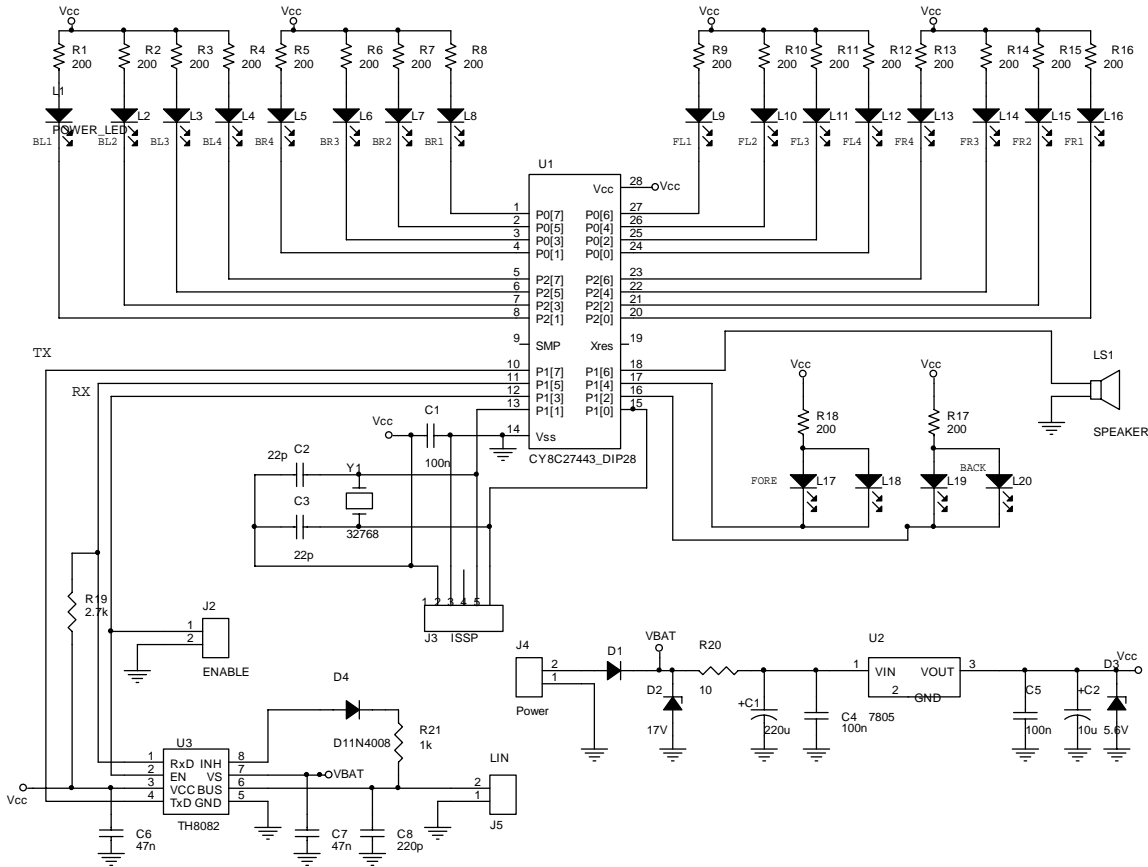

Figure 15. Schematic of Parking Assistant with LIN Master

The two middle LEDs on each bar graph indicate the status of LIN bus communication. If they are blinking, communication with the LIN slave is absent. When lit, communication is occurring. When LEDs fade, the parking assistant is inactive. Measured distances are indicated by the lit LEDs on these bar graphs. The back-end and front-end LED bar graphs are divided in two, left and right (see Figure 16).

The master device identifies the minimum distance for front/rear and right/left sensor groups and uses these values for display. There are 9 logic levels that indicate the distance to obstacles (Figure 17).

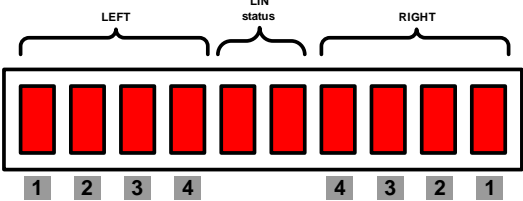

Figure 16. LED Matrix Description

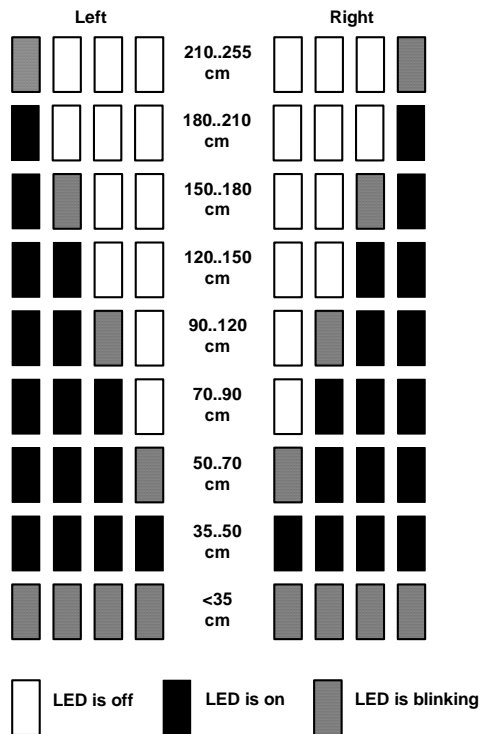

Figure 17. Distance Indication Table

When the vehicle approaches an obstacle that is within 90 cm, the alarm sounds. The alarm has four different signaling levels, which change by varied signals/pauses.

Table 2. Levels and Conditions of Alarm Signal

Distance cm	Alarm Signal
<35	Continued, No Pause
35..50	50% Pause
50..70	75% Pause
70..90	87% Pause
> 90	No Sound

LIN Master Setup

The LIN bus interface settings for the master device complement the parking assistant LIN slave.

- o Message ID for reading distance values: 0x1002
- o Protection ID for reading distance values: 0x9C
- o Speed in bps: 19200
- o Supplier ID: 0x1234

Master Device Photo

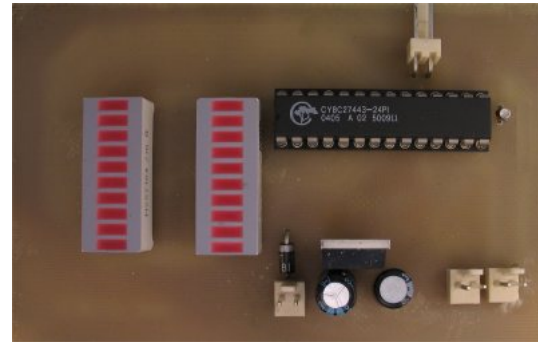

Figure 18. Parking Assistant LIN Master Device Top View

Conclusion

This Application Note describes the parking assistant with LIN Bus 2.0 interface. Modifications can be made to accommodate special customer requirements. For example, the 8-channel parking assistant may include indication and alarm functions located on one device (Figure 19).

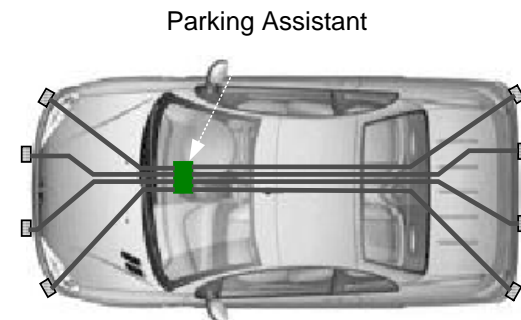

Figure 19. Parking Assistant Without LIN Bus

Ultrasonic sensor implementation may be used for applications similar to the parking assistant.

Additionally, the application may be used in a navigational system (TFT or plasma display to graphically show measured distance for each sensor), integrated into a collision avoidance system.

About the Author

Name: Valeriy Kyrynyuk

Title: Engineer

Background: Seven years experience with fieldbus and communication device design.

Contact: lopik@lviv.farlep.net

Cypress Semiconductor
2700 162nd Street SW, Building D
Lynnwood, WA 98037
Phone: 800.669.0557
Fax: 425.787.4641

<http://www.cypress.com/>

Copyright © 2005 Cypress Semiconductor Corporation. All rights reserved.

"Programmable System-on-Chip," PSoC, PSoC Designer and PSoC Express are trademarks of Cypress Semiconductor Corp.

All other trademarks or registered trademarks referenced herein are the property of their respective owners.

The information contained herein is subject to change without notice. Made in the U.S.A.